

TPE Triple Fin Smoke Seal

Properties:

- Thermo-Plastic Elastomer (TPE)
- Good abrasion resistance
- Moisture resistant
- BHMA certified to ANSI/BHMA A156.22 performance tests for heat, cold, air infiltration and energy performance
- Adhesive specifications shown on page G9
- Rigid base with flexible elastomeric fins
- Flame resistant
- Temperature range -60°F to 275°F
- Anti-microbial: treated with an anti-microbial additive to inhibit the growth of microorganisms
- REACH and RoHS compliant

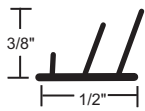

5075B Brown
5075C Charcoal
5075CL Clear
5075W White



*Anti-microbial not available in clear

Available in 36", 48", 72", 84", 96" and 108" lengths

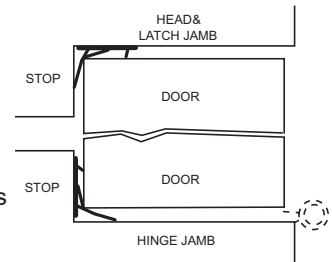

Thermoplastic Door Shoe with Soft Vinyl Fins

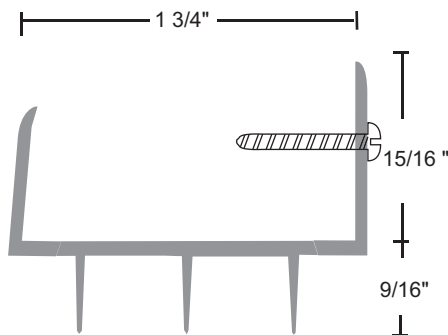

344-36" Dark Brown
344-48"
344C-36" Black

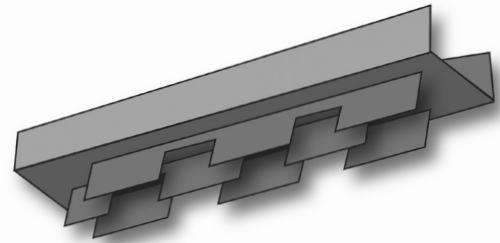

Available with Notched Fins "NF" to allow air flow while restricting light infiltration.

344CNF-36" Black
344NF-36" Dark Brown
344NF-48"

